



VILLAGE OF MOUNT HOREB

E. Main Street

Mount Horeb, WI 53572

Phone: (608) 437-6884 Fax: (608) 437-3190

Email: mhinfo@mounthorebwi.info Web: mounthorebwi.info

PARKS, RECREATION, AND FORESTRY COMMISSION AGENDA

Tuesday, July 22, 2025 at 5:30 PM

Municipal Building Board Room

138 E. Main Street

Mount Horeb, WI

- 1) Call to order
- 2) Roll call
- 3) Public Comments
- 4) Consent agenda
 - a. Consideration of June 24, 2025 meeting minutes
- 5) Agenda Items
 - a. Lukken Property Update
 - b. Summer Frolic Update
 - c. Grundahl Park fan and electric update
 - d. Grandma Foster Playground Equipment Discussion
 - e. Katie Hartman - Request for spots in Village Parks for yard in a yard program
 - f. Capital Budget Requests
- 6) Department Reports
 - a. Recreation Director's Report
 - b. Public Services Director's Report
- 7) Future agenda items
- 8) Set next meeting date and time
- 9) Meeting adjournment

UPON REASONABLE NOTICE, EFFORTS WILL BE MADE TO ACCOMMODATE THE NEEDS OF DISABLED INDIVIDUALS THROUGH APPROPRIATE AIDS AND SERVICES. FOR INFORMATION OR TO REQUEST THIS SERVICE, CONTACT ALYSSA GAFFNEY, CLERK, AT 138 E MAIN STREET, MOUNT HOREB, WI (608) 437-9404.

MINUTES

PARKS, RECREATION AND FORESTRY COMMISSION

June 24, 2025, 5:30 PM, Municipal Building Board Room

PRESENT: Halverson, Adler, White, Arrigoni, Webber

ABSENT: Hogseth, Honore

OTHERS PRESENT: Owen, Gorman, Dudley – Village of Mount Horeb

Consider minutes of the April 22, 2025 meeting.

White moved; Adler seconded to approve the minutes of the April 22, 2025 meeting. Motion carried.

Consider request from Kyle Keene to allow alcohol in Grundahl Park from 11pm to 1am on July 26-27 for the musicians at the Mount Horeb Country Music Faire

Keene asked to allow the musicians to consume liquor/alcohol in the back stage area of Grundahl Park during those dates and times. There would be no sale of alcohol at that time. Webber moved, White seconded to approve the consumption of alcohol in the back stage areas of Grundahl Park during the Country Music Faire. Motion carried.

Discuss Grundahl Park scorekeeper's building plans/architect status

Adler stated that the draft plans had been sent to the architect but it would be about two months before he could look at them, so there is no update at this time.

Lukken property master planning update/concept plan review

Staff met today with JSD to review two concept plans. We were looking at having a public review session in early July, but with some changes needed to the plans, we are pushing that back to late July.

Foster Park playground update

Gorman said he is meeting with Gerber Leisure Products in two days to review the site and discuss revising the 2021 playground plans and increase the footprint from the original design to allow swings or other features. He hopes to have preliminary designs and budget number by the July meeting.

Discuss electrical pedestals at Grundahl Park

Adler said that pedestal by the ticket trailer will be replaced which will complete the upgrade in the beer tent/stage area. A second pedestal located by the octagon shelter will likely be eliminated for lack of need and we would get a refund from the electrician on that pedestal.

Discuss Grundahl Park enclosed shelter/restroom building

Gorman stated that there were some issues that came up at the restroom shelter during the Frolic. The hot water heater stopped working, a urinal was plugged and a flush handle was not operating correctly on a women's toilet. Gorman said all three items were repaired by Ron Haag Plumbing on June 20. Adler suggested upgrading the lights and the ceiling fan in the shelter. Gorman will get estimates on the upgrades. Adler said the Frolic may be able to help with the cost.

Recreation Director's Report

Dudley reviewed her written report

Public Services Director's Report

Gorman reviewed his written report.

Future agenda items

- Grundahl scorekeeper's building/architect
- Budget
- Foster Park playground
- JSD update
- Grundahl shelter lights and fan upgrade

Set next meeting date and time

July 22, 2025 at 5:30 pm

Adjourn

White moved, Adler seconded to adjourn at 5:56 pm. Motion carried.

Minutes prepared by Jeff Gorman, Public Services Director

DRAFT



AGENDA ITEM REPORT

MEETING DATE

July 22, 2025

PREPARED BY

AGENDA ITEM # 5.a

Lukken Property Update

BACKGROUND

RECOMMENDATION

ATTACHMENTS

None



AGENDA ITEM REPORT

MEETING DATE	PREPARED BY
July 22, 2025	
AGENDA ITEM # 5.b	
Summer Frolic Update	
BACKGROUND	
RECOMMENDATION	
ATTACHMENTS	
None	



AGENDA ITEM REPORT

MEETING DATE

July 22, 2025

PREPARED BY

AGENDA ITEM # 5.c

Grundahl Park fan and electric update

BACKGROUND

RECOMMENDATION

ATTACHMENTS

None



AGENDA ITEM REPORT

MEETING DATE

July 22, 2025

PREPARED BY

Jeff Gorman, Public Services
Director

AGENDA ITEM # 5.d

Grandma Foster Playground Equipment Discussion

BACKGROUND

Gerber Leisure Products provided two options for playground design at Grandma Foster Park. They were able to include a Toddler Swing in both designs. Option One features a more modern design, while Option Two offers a more traditional design with some modern components. Both designs include independent play elements for the 2-5 age group in addition to the swings. Option 2 has a few more for this age group.

These designs are primarily for budgeting purposes. We can make changes to the designs if the budget is approved.

RECOMMENDATION

ATTACHMENTS

1. Foster park playground option 1 2025
2. Foster park playground option 2 2025



Grandma Foster Park



Opt1 • 7.14.2025

© 2025 Landscape Structures. All Rights Reserved



Grandma Foster Park



Opt1 • 7.14.2025

© 2025 Landscape Structures. All Rights Reserved



Grandma Foster Park



Opt1 • 7.14.2025

© 2025 Landscape Structures. All Rights Reserved



Grandma Foster Park



Opt1 • 7.14.2025

© 2025 Landscape Structures. All Rights Reserved



Grandma Foster Park



Opt1 • 7.14.2025

© 2025 Landscape Structures. All Rights Reserved



Grandma Foster Park

Opt1 • 7.14.2025



© 2025 Landscape Structures. All Rights Reserved



The play components identified on this plan are IREMA certified. (Unless model number is preceded with *) The use and layout of these components conform to the requirements of ASTM F1487. To verify product certification, visit www.irema.org

THIS PLAY AREA & PLAY EQUIPMENT IS DESIGNED FOR AGES 2-12 YEARS UNLESS OTHERWISE NOTED ON PLAN.

IT IS THE MANUFACTURER'S OPINION THAT THIS PLAY AREA DOES CONFORM TO THE A.D.A. ACCESSIBILITY STANDARDS, ASSUMING AN ACCESSIBLE PROTECTIVE SURFACING IS PROVIDED, AS INDICATED, OR WITHIN THE ENTIRE USE ZONE.

THIS CONCEPTUAL PLAN WAS BASED ON INFORMATION AVAILABLE TO US. PRIOR TO CONSTRUCTION, DETAILED SITE INFORMATION INCLUDING SITE DIMENSIONS, TOPOGRAPHY, EXISTING UTILITIES, SOIL CONDITIONS, AND DRAINAGE SOLUTIONS SHOULD BE OBTAINED, EVALUATED, & UTILIZED IN THE FINAL DESIGN. PLEASE VERIFY ALL DIMENSIONS OF PLAY AREA, SIZE, ORIENTATION, AND LOCATION OF ALL EXISTING UTILITIES, EQUIPMENT, AND SITE FURNISHINGS PRIOR TO ORDERING. SLIDES SHOULD NOT FACE THE HOT AFTERNOON SUN.

CHOOSE A PROTECTIVE SURFACING MATERIAL THAT HAS A CRITICAL HEIGHT VALUE TO MEET THE MAXIMUM FALL HEIGHT FOR THE EQUIPMENT (REF. ASTM F1487 STANDARD CONSUMER SAFETY PERFORMANCE SPECIFICATION FOR PLAYGROUND EQUIPMENT FOR PUBLIC USE, SECTION 8. CURRENT REVISION). THE SUBSURFACE MUST BE WELL DRAINED. IF THE SOIL DOES NOT DRAIN NATURALLY IT MUST BE TILED OR SLOPED 1/8" TO 1/4" PER FOOT TO A STORM SEWER OR A "FRENCH DRAIN".

AREA OF ACCESSIBLE/PROTECTIVE LOOSE-FILL MATERIAL (ENGINEERED WOOD FIBER SUGGESTED) 1,915 SQ. FT.

IT IS THE MANUFACTURER'S OPINION AND INTENT THAT THE LAYOUT OF THESE COMPONENTS CONFORM WITH THE U.S. CONSUMER PRODUCT SAFETY COMMISSION'S (CPSC) "HANDBOOK FOR PUBLIC PLAYGROUND SAFETY".

DESIGNED BY:
KLP

COPYRIGHT: 7/8/25
LANDSCAPE STRUCTURES, INC.
601 7th STREET SOUTH - P.O. BOX 198
DELANO, MINNESOTA 55328
PH: 1-800-328-0035 FAX: 1-763-972-6091

Date	Previous Drawing #	Initials

S WASHINGTON STREET

EXISTING WALKWAY

10" CONCRETE BORDER
120 LN. FT

5-12 YEARS

64'-7"

2-5 YEARS

EXISTING SHELTER

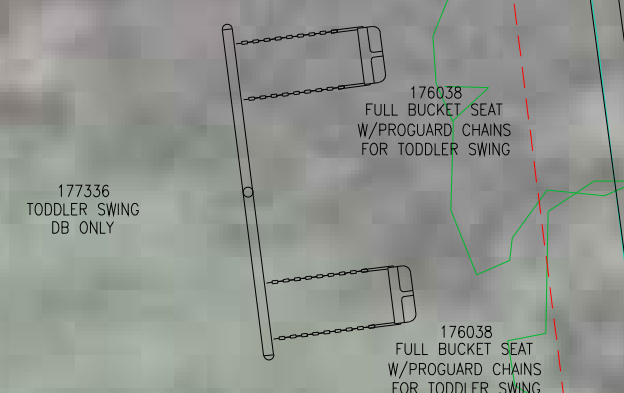
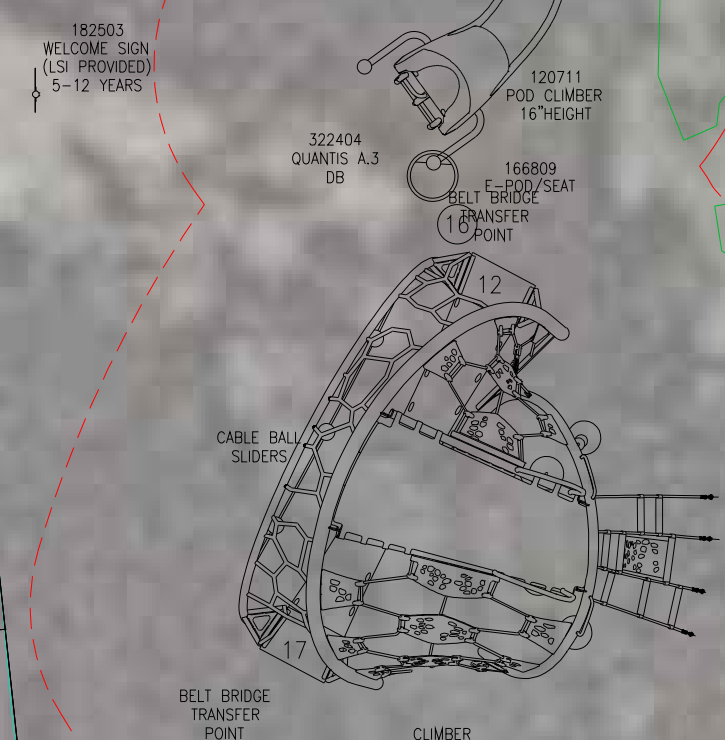

5-12 YEARS
Handmade and Custom
Max Fall Height: 63 inches

TOTAL ELEVATED PLAY COMPONENTS	0	REQUIRED	0
TOTAL ELEVATED COMPONENTS ACCESSIBLE BY RAMP	0	REQUIRED	0
TOTAL ELEVATED COMPONENTS ACCESSIBLE BY TRANSFER	0	REQUIRED	0
TOTAL ACCESSIBLE GROUND LEVEL COMPONENTS SHOWN	5	REQUIRED	0
TOTAL DIFFERENT TYPES OF GROUND LEVEL COMPONENTS	4	REQUIRED	4

2-5 YEARS
Freestanding Play
(2-5 years)
Max Fall Height: 73 inches

TOTAL ELEVATED PLAY COMPONENTS	0	REQUIRED	0
TOTAL ELEVATED COMPONENTS ACCESSIBLE BY RAMP	0	REQUIRED	0
TOTAL ELEVATED COMPONENTS ACCESSIBLE BY TRANSFER	0	REQUIRED	0
TOTAL ACCESSIBLE GROUND LEVEL COMPONENTS SHOWN	3	REQUIRED	0
TOTAL DIFFERENT TYPES OF GROUND LEVEL COMPONENTS	2	REQUIRED	2

RED OUTLINE BARRIERS ARE SAFETY USE ZONES - DO NOT ENCROACH PER ASTM F1487

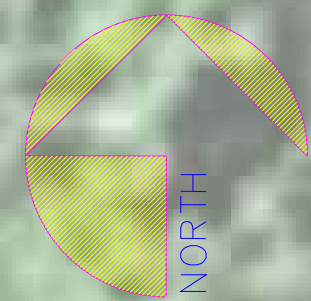
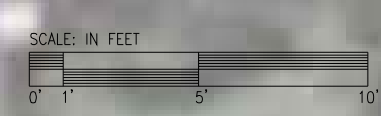

Grandma Foster Park
Option One
Mount Horeb, WI

Gerber Leisure
Products, Inc.
Kyla Reamon

SYSTEM TYPE:
Multi-system

DRAWING #:
1198497-01-01





The play components certified on this plan are IPEMA certified. (Unless model number is preceded with *) The use and layout of these components conform to the requirements of ASTM F1487. To verify product certification, visit www.ipema.org

THIS PLAY AREA & PLAY EQUIPMENT IS DESIGNED FOR AGES 2-12 YEARS UNLESS OTHERWISE NOTED ON PLAN.

IT IS THE MANUFACTURERS OPINION THAT THIS PLAY AREA DOES CONFORM TO THE A.D.A. ACCESSIBILITY STANDARDS, ASSUMING AN ACCESSIBLE PROTECTIVE SURFACING IS PROVIDED, AS INDICATED, OR WITHIN THE ENTIRE USE ZONE.

THIS CONCEPTUAL PLAN WAS BASED ON INFORMATION AVAILABLE TO US. PRIOR TO CONSTRUCTION, DETAILED SITE INFORMATION INCLUDING SITE DIMENSIONS, TOPOGRAPHY, EXISTING UTILITIES, SOIL CONDITIONS, AND DRAINAGE SOLUTIONS SHOULD BE OBTAINED, EVALUATED, & UTILIZED IN THE FINAL DESIGN. PLEASE VERIFY ALL DIMENSIONS OF PLAY AREA, SIZE, ORIENTATION, AND LOCATION OF ALL EXISTING UTILITIES, EQUIPMENT, AND SITE FURNISHINGS PRIOR TO ORDERING. SLIDES SHOULD NOT FACE THE HOT AFTERNOON SUN.

CHOOSE A PROTECTIVE SURFACING MATERIAL THAT HAS A CRITICAL HEIGHT VALUE TO MEET THE MAXIMUM FALL HEIGHT FOR THE EQUIPMENT (REF. ASTM F1487 STANDARD CONSUMER SAFETY PERFORMANCE SPECIFICATION FOR PLAYGROUND EQUIPMENT FOR PUBLIC USE, SECTION 8 CURRENT REVISION). THE SUBSURFACE MUST BE WELL DRAINED. IF THE SOIL DOES NOT DRAIN NATURALLY IT MUST BE TILED OR SLOPED 1/8" TO 1/4" PER FOOT TO A STORM SEWER OR A "FRENCH DRAIN".

AREA OF ACCESSIBLE/PROTECTIVE LOOSE-FILL MATERIAL (ENGINEERED WOOD CHIPS/SUBJECT) 1,915 SQ FT

IT IS THE MANUFACTURER'S OPINION AND INTENT THAT THE LAYOUT OF THESE COMPONENTS CONFORM WITH THE U.S. CONSUMER PRODUCT SAFETY COMMISSION'S (CPSC) "HANDBOOK FOR PUBLIC PLAYGROUND SAFETY".

DESIGNED BY:
KLP

COPYRIGHT: 7/8/25
LANDSCAPE STRUCTURES, INC.
601 7th STREET SOUTH - P.O. BOX 198
DELAND, MINNESOTA 55328
PH: 1-800-328-0035 FAX: 1-763-972-6091

Date	Previous Drawing #	Initials



5-12 YEARS
PlayBooster and Quantis (5-12 years)
Max Fall Height: 83 inches

2-5 YEARS
Freestanding Play (2-5 years)
Max Fall Height: 73 inches

TOTAL ELEVATED PLAY COMPONENTS	0	REQUIRED	0
TOTAL ELEVATED COMPONENTS ACCESSIBLE BY RAMP	0	REQUIRED	0
TOTAL ELEVATED COMPONENTS ACCESSIBLE BY TRANSFER	0	REQUIRED	0
TOTAL ACCESSIBLE GROUND LEVEL COMPONENTS SHOWN	5	REQUIRED	0
TOTAL DIFFERENT TYPES OF GROUND LEVEL COMPONENTS	4	REQUIRED	4

TOTAL ELEVATED PLAY COMPONENTS	0	REQUIRED	0
TOTAL ELEVATED COMPONENTS ACCESSIBLE BY RAMP	0	REQUIRED	0
TOTAL ELEVATED COMPONENTS ACCESSIBLE BY TRANSFER	0	REQUIRED	0
TOTAL ACCESSIBLE GROUND LEVEL COMPONENTS SHOWN	3	REQUIRED	0
TOTAL DIFFERENT TYPES OF GROUND LEVEL COMPONENTS	2	REQUIRED	2

RED OUTLINE BARRIERS ARE SAFETY USE ZONES - DO NOT ENCR OACH PER ASTM F1487

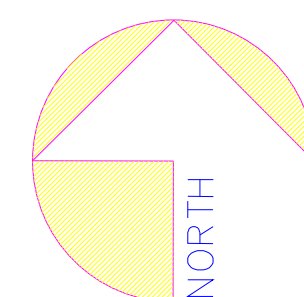
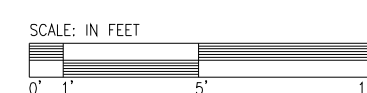

Grandma Foster Park
Option One
Mount Horeb, WI

Gerber Leisure
Products, Inc.
Kyla Reamon

SYSTEM TYPE:
Multi-system

DRAWING #:
1198497-01-01





Freestanding Play (2-5 years)

* Palette Overridden *

PHASE-1 Direct Bury Aluminum

!! Palette NOT Selected !!



Swings

Posts: **Tangerine ***
Beams: **Limon ***

QTY	NUMBER	DESCRIPTION
-----	--------	-------------

**Freestanding Play
Motion & More Fun**

1	233059B	Digifuse® TuffRiders® Bear Direct Bury
---	---------	--

Swings

2	176038G	Full Bucket Seat ProGuard Chains for Toddler Swing
---	---------	--

1	177336A	Toddler Swing Frame DB Only
---	---------	-----------------------------

Posts: Tangerine=319
Beams: Limon=317

PlayBooster and Quantis (5-12 years)

* Palette Overridden *

PHASE-1 Direct Bury Aluminum

!! Palette NOT Selected !!



ProShield® Finish

Posts/Arches: **Purple ***
Clamps/Ball Connectors: **Tangerine ***
Play Components: **Peacock ***

Polyethylene

Slides/Tunnels/Gliders/E-Pods®: **Limon ***

Cables

Cables: **Black ***

Swings

Molded Bucket Seats: **Tangerine ***

QTY	NUMBER	DESCRIPTION
-----	--------	-------------

Climbers

1	120711A	Pod Climber 16" DB
---	---------	--------------------

Play Components: Peacock=419

Slides/Tunnels/Gliders/E-Pods®: Limon=317

Signs

1	182503C	Welcome Sign (LSI Provided) Ages 5-12 years Direct Bury
---	---------	---

Posts/Arches: Purple=027



Surfacing

4	100626A	Stake 30" Stl TuffTimber
1	130799A	TuffTimbers Access Wedge

PlayBooster®

Motion & More Fun

1	166809A	E-Pod Seat
---	---------	-------------------

Clamps/Ball Connectors:  Tangerine=319

Slides/Tunnels/Gliders/E-Pods®:  Limon=317

Posts

2	111404F	108" Alum Post DB
---	---------	--------------------------

Posts/Arches:  Purple=027

Slides

1	183176A	Rush™ Slide DB Only
---	---------	----------------------------

Posts/Arches:  Purple=027

Clamps/Ball Connectors:  Tangerine=319

Play Components:  Peacock=419

Slides/Tunnels/Gliders/E-Pods®:  Limon=317

Quantis®

Ages 5-12 Yrs

1	322404A	Quantis® A.3 DB ¹
---	---------	-------------------------------------

Posts/Arches:  Purple=027

Play Components:  Peacock=419

Slides/Tunnels/Gliders/E-Pods®:  Limon=317

Cables:  Black=005

Molded Bucket Seats:  Tangerine=319



Gerber Leisure Products, INC.

PO Box 42
Mount Horeb, WI 53572

Phone: 800-236-7758

Prepared by: Kyla Reamon - kyla@gerberleisure.com

QUOTE

DATE:	7/15/2025
QUOTE Name:	Option One Modern Structure
Valid Until:	30 days

Customer
Village of Mount Horeb
Grandma Foster Park 211 W Main S Mt Horeb, WI 53572

DESCRIPTION	QTY	PRICE	AMOUNT
New Landscape Structures play equipment, per attached 2D, 3Ds & Component List	1	50049.6	50,049.60
<i>Discount on equipment, per Kyla</i>	1	-3949.6	-3,949.60
Freight to installer	1	1400	1,400.00
			0.00
Professional installation of above listed equipment	1	16365	16,375.00
<i>Local customer installation discount, per Kyla</i>	1	-2500	-2,500.00
Certified playground wood fiber surfacing, delivered and installed	1	4550	4,550.00
Concrete border per plans - 120 lineal ft. *10" Wide X 4" depth with rebar cable quoted	1	2225	2,225.00
To be completed by Village of Mount Horeb representatives			0.00
Removal and disposal of existing playground equipment Excavation, site prep/leveling per plans Marking of private lines, fire lanes and obtaining permits Site restoration/reseeding Removal of any tree limbs			0.00
<i>The equipment that I have proposed would comply with the current ADA guidelines in and of itself assuming that accessible resilient surfacing is supplied underneath the equipment including under and around the auxiliary ground level equipment, and an access pathway to the area is provided</i>			

TERMS AND CONDITIONS

- All invoices will be sent via QuickBooks. A 3% CC fee will be applied to any CC payments.
- Full payment of materials is due to place the order **\$47,500.00**
- Customer will be billed for applicable installation services and surfacing materials/services at start of work
- Additional agreed upon services will be billed upon completion of the project
- Final payment will be due within 30 days of invoice date, a late fee of 3% per month will be added to any late payments
- Please mail or email signed price quote to the address above
Customer Acceptance (sign below):

Subtotal	\$68,150.00
Taxable	\$0.00
Tax rate	0.000%
Tax due	\$0.00
Other	\$0.00
TOTAL Due	\$68,150.00

x _____
Print Name:

If you have any questions about this price quote, please contact: Kyla Reamon at 608-437-7037 / kyla@gerberleisure.com

Thank You For Your Business!

Gerber Leisure Products, INC.

PO Box 42
 Mount Horeb, WI 53572
 Phone: 800-236-7758

Prepared by: Kyla Reamon - kyla@gerberleisure.com

QUOTE

DATE:	7/15/2025
QUOTE Name:	Inclusions
Valid Until:	30 days

Customer
Village of Mount Horeb
Grandma Foster Park 211 W Main S Mt Horeb, WI 53572

DESCRIPTION	Includes	Does NOT Include
New Landscape Structures play equipment, per attached 2D, 3Ds & Component List	all equipment listed and shown on corresponding documents	discounts, shipping, installation, surfacing
Discount on equipment, per Kyla	discount from manufacturer LIST pricing of equipment	discounts of any other kind, unless included in this quote
Freight to installer	safe delivery of the listed equipment to a previously agreed upon location, or our installers warehouse for storage	unloading of freight
Professional installation of above listed equipment	digging footing holes, assembly of equipment, concrete for footings, project management, calling diggers, coordination of materials	excavation, site prep/leveling, surfacing, installation of surfacing, private lines marking or responsibility
Discount for local customer, per Kyla	discount from installation pricing of the playground equipment	discounts of any other kind, unless included in this quote
Certified playground wood fiber	materials, shipping, installation	fabric, drain tile
To be completed by Village of Mount Horeb representatives		
Removal and disposal of existing playground equipment		
Excavation, site prep/leveling per plans		
Marking of private lines, fire lanes and obtaining permits		
Site restoration/reseeding		
Removal of any tree limbs in the playspace		
<p><i>The equipment that I have proposed would comply with the current ADA guidelines in and of itself assuming that accessible resilient surfacing is supplied underneath the equipment including under and around the auxiliary ground level equipment, and an access pathway to the area is provided</i></p>		

TERMS AND CONDITIONS

1. Full payment on materials is due to place the order.
 2. Customer will be billed for applicable installation services at start of work
 3. Additional services (surfacing) will be billed upon completion of the project
 4. Payment will be due within 30 days of invoice date
 5. Please mail or email signed price quote to the address above
- Customer Acceptance (sign below):*

x _____
 Print Name:

If you have any questions about this price quote, please contact: Kyla Reamon at 608-437-7037 / kyla@gerberleisure.com

Thank You For Your Business!

Option One Component List

Date:07/14/2025

Rep Organization: Gerber Leisure
Products, Inc.

Quote No: Opt1

By:KLP

Contact Person: Kyla Reamon

Project Title: Grandma Foster Park

Location: Mount Horeb, WI

Freestanding Play (2-5 years)						
PHASE-1 Direct Bury Aluminum			UNIT		TOTAL	
QTY	NO.	DESCRIPTION	WEIGHT (lb)	PRICE (US \$)	WEIGHT (lb)	PRICE (2025)
Freestanding Play						
Motion & More Fun						
1	233059B	DigiRider Bear DB			85.0	1,830.00
Swings						
2	176038G	Full Bucket Seat ProGuard Chains for Toddler Swing	11.0	460.00	22.0	920.00
1	177336A	Toddler Swing Frame DB Only			136.0	1,470.00
PlayBooster and Quantis (5-12 years)						
PHASE-1 Direct Bury Aluminum			UNIT		TOTAL	
QTY	NO.	DESCRIPTION	WEIGHT (lb)	PRICE (US \$)	WEIGHT (lb)	PRICE (2025)
PlayBooster®						
Motion & More Fun						
1	166809A	E-Pod Seat			11.0	415.00
Posts						
2	111404F	108" Alum Post DB	28.0	395.00	56.0	790.00
Slides						
1	183176A	Rush Slide DB Only			255.0	6,140.00
Quantis®						
Ages 5-12 Yrs						
1	322404A	Quantis A.3 DB ¹			1250.0	36,875.00
Freestanding Play						
Climbers						
1	120711A	Pod Climber 16" DB			14.0	375.00
Signs						
1	182503C	Welcome Sign (LSI Provided) Ages 5-12 years Direct Bury			24.0	0.00
Surfacing						
4	100626A	30" Galvanized Stake	4.0	18.65	16.0	74.60
1	130799A	TuffTimbers Access Wedge			90.0	1,160.00

Option One Component List

Date:07/14/2025

Rep Organization: Gerber Leisure
Products, Inc.

Quote No: Opt1

By:KLP

Contact Person: Kyla Reamon

Project Title: Grandma Foster Park

Location: Mount Horeb, WI

SUMMARY		WEIGHT (lb)	PRICE (2025)
Freestanding Play (2-5 years) PHASE-1		243.0	4,220.00
Total Safety Zone Area = 1177 sq. ft.			
PlayBooster and Quantis (5-12 years) PHASE-1		1,716.0	45,829.60
Total Safety Zone Area = 704 sq. ft.			
ALL PHASES	Freestanding Play	387.0	5,829.60
	PlayBooster®	322.0	7,345.00
	Quantis®	1,250.0	36,875.00
	Total	1,959.0	50,049.60



Grandma Foster Park



Opt2 • 7.14.2025

© 2025 Landscape Structures. All Rights Reserved



landscape structures

Grandma Foster Park

gerber
leisure products

Opt2 • 7.14.2025

© 2025 Landscape Structures. All Rights Reserved



Grandma Foster Park



Opt2 • 7.14.2025

© 2025 Landscape Structures. All Rights Reserved



Grandma Foster Park



Opt2 • 7.14.2025

© 2025 Landscape Structures. All Rights Reserved



Grandma Foster Park



Opt2 • 7.14.2025

© 2025 Landscape Structures. All Rights Reserved



Grandma Foster Park



Opt2 • 7.14.2025

© 2025 Landscape Structures. All Rights Reserved



Grandma Foster Park



Opt2 • 7.14.2025

© 2025 Landscape Structures. All Rights Reserved



Grandma Foster Park



Opt2 • 7.14.2025



The play components identified on this plan are IREMA certified. (Unless model number is preceded with *) The use and layout of these components conform to the requirements of ASTM F1487. To verify product certification, visit www.irema.org

THIS PLAY AREA & PLAY EQUIPMENT IS DESIGNED FOR AGES 2-12 YEARS UNLESS OTHERWISE NOTED ON PLAN.

IT IS THE MANUFACTURER'S OPINION THAT THIS PLAY AREA DOES CONFORM TO THE A.D.A. ACCESSIBILITY STANDARDS, ASSUMING AN ACCESSIBLE PROTECTIVE SURFACING IS PROVIDED, AS INDICATED, OR WITHIN THE ENTIRE USE ZONE.

THIS CONCEPTUAL PLAN WAS BASED ON INFORMATION AVAILABLE TO US. PRIOR TO CONSTRUCTION, DETAILED SITE INFORMATION INCLUDING SITE DIMENSIONS, TOPOGRAPHY, EXISTING UTILITIES, SOIL CONDITIONS, AND DRAINAGE SOLUTIONS SHOULD BE OBTAINED, EVALUATED, & UTILIZED IN THE FINAL DESIGN. PLEASE VERIFY ALL DIMENSIONS OF PLAY AREA, SIZE, ORIENTATION, AND LOCATION OF ALL EXISTING UTILITIES, EQUIPMENT, AND SITE FURNISHINGS PRIOR TO ORDERING. SLIDES SHOULD NOT FACE THE HOT AFTERNOON SUN.

CHOOSE A PROTECTIVE SURFACING MATERIAL THAT HAS A CRITICAL HEIGHT VALUE TO MEET THE MAXIMUM FALL HEIGHT FOR THE EQUIPMENT (REF. ASTM F1487 STANDARD CONSUMER SAFETY PERFORMANCE SPECIFICATION FOR PLAYGROUND EQUIPMENT FOR PUBLIC USE, SECTION 8 CURRENT REVISION). THE SUBSURFACE MUST BE WELL DRAINED. IF THE SOIL DOES NOT DRAIN NATURALLY IT MUST BE TILED OR SLOPED 1/8" TO 1/4" PER FOOT TO A STORM SEWER OR A "FRENCH DRAIN".

ACCESSIBLE/PROTECTIVE
LOOSE FILL MATERIAL
(ENGINEERED WOOD FIBER SUGGESTED)
1,915 SQ. FT.

IT IS THE MANUFACTURER'S OPINION AND INTENT THAT THE LAYOUT OF THESE COMPONENTS CONFORM WITH THE U.S. CONSUMER PRODUCT SAFETY COMMISSION'S (CPSC) "HANDBOOK FOR PUBLIC PLAYGROUND SAFETY".

DESIGNED BY:
KLP

COPYRIGHT: 7/8/25
LANDSCAPE STRUCTURES, INC.
601 7th STREET SOUTH - P.O. BOX 198
DELANO, MINNESOTA 55328
PH: 1-800-328-0035 FAX: 1-763-972-6091

Date	Previous Drawing #	Initials

S WASHINGTON STREET



5-12 YEARS PlayBooster (5-12 years) Max Fall Height: 72 inches

TOTAL ELEVATED PLAY COMPONENTS	6		
TOTAL ELEVATED COMPONENTS ACCESSIBLE BY RAMP	0	REQUIRED	0
TOTAL ELEVATED COMPONENTS ACCESSIBLE BY TRANSFER	5	REQUIRED	3
TOTAL ACCESSIBLE GROUND LEVEL COMPONENTS SHOWN	3	REQUIRED	2
TOTAL DIFFERENT TYPES OF GROUND LEVEL COMPONENTS	3	REQUIRED	3

2-5 YEARS Transferring via Low Ladders Max Fall Height: 72 inches

TOTAL ELEVATED PLAY COMPONENTS	0		
TOTAL ELEVATED COMPONENTS ACCESSIBLE BY RAMP	0	REQUIRED	0
TOTAL ELEVATED COMPONENTS ACCESSIBLE BY TRANSFER	0	REQUIRED	0
TOTAL ACCESSIBLE GROUND LEVEL COMPONENTS SHOWN	7	REQUIRED	0
TOTAL DIFFERENT TYPES OF GROUND LEVEL COMPONENTS	6	REQUIRED	6

RED OUTLINE BARRIERS ARE SAFETY USE ZONES - DO NOT ENCR OACH PER ASTM F1487

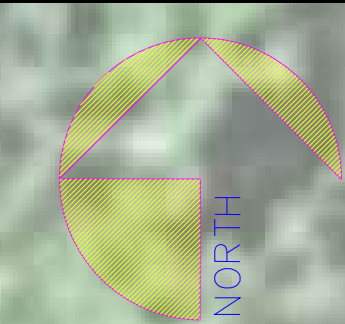
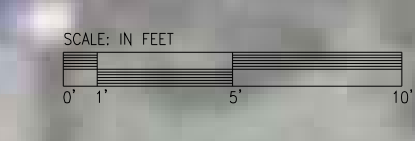

Grandma Foster Park
Option Two
Mount Horeb, WI

Gerber Leisure
Products, Inc.
Kyla Reamon

SYSTEM TYPE:
Multi-system

DRAWING #:
1198497-02-01

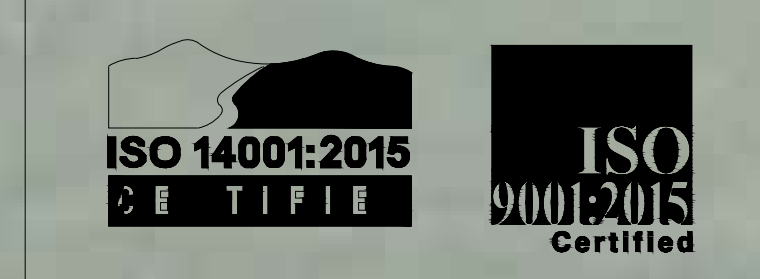



The play components certified on this plan are IPEMA certified. (Unless model number is preceded with *) The use and layout of these components conform to the requirements of ASTM F1487. To verify product certification, visit www.ipema.org

THIS PLAY AREA & PLAY EQUIPMENT IS DESIGNED FOR AGES 2-12 YEARS UNLESS OTHERWISE NOTED ON PLAN.

IT IS THE MANUFACTURERS OPINION THAT THIS PLAY AREA DOES CONFORM TO THE A.D.A. ACCESSIBILITY STANDARDS, ASSUMING AN ACCESSIBLE PROTECTIVE SURFACING IS PROVIDED, AS INDICATED, OR WITHIN THE ENTIRE USE ZONE.

THIS CONCEPTUAL PLAN WAS BASED ON INFORMATION AVAILABLE TO US. PRIOR TO CONSTRUCTION, DETAILED SITE INFORMATION INCLUDING SITE DIMENSIONS, TOPOGRAPHY, EXISTING UTILITIES, SOIL CONDITIONS, AND DRAINAGE SOLUTIONS SHOULD BE OBTAINED, EVALUATED, & UTILIZED IN THE FINAL DESIGN. PLEASE VERIFY ALL DIMENSIONS OF PLAY AREA, SIZE, ORIENTATION, AND LOCATION OF ALL EXISTING UTILITIES, EQUIPMENT, AND SITE FURNISHINGS PRIOR TO ORDERING. SLIDES SHOULD NOT FACE THE HOT AFTERNOON SUN.

CHOOSE A PROTECTIVE SURFACING MATERIAL THAT HAS A CRITICAL HEIGHT VALUE TO MEET THE MAXIMUM FALL HEIGHT FOR THE EQUIPMENT (REF. ASTM F1487 STANDARD CONSUMER SAFETY PERFORMANCE SPECIFICATION FOR PLAYGROUND EQUIPMENT FOR PUBLIC USE, SECTION 8 CURRENT REVISION). THE SUBSURFACE MUST BE WELL DRAINED. IF THE SOIL DOES NOT DRAIN NATURALLY IT MUST BE TILED OR SLOPED 1/8" TO 1/4" PER FOOT TO A STORM SEWER OR A "FRENCH DRAIN".

ACCESSIBLE/PROTECTIVE
LOOSE FILL MATERIAL
(ENGINEERED WOOD FIBER SUGGESTED)
1,915 SQ FT

IT IS THE MANUFACTURER'S OPINION AND INTENT THAT THE LAYOUT OF THESE COMPONENTS CONFORM WITH THE U.S. CONSUMER PRODUCT SAFETY COMMISSION'S (CPSC) "HANDBOOK FOR PUBLIC PLAYGROUND SAFETY".

DESIGNED BY:
KLP

COPYRIGHT: 7/8/25
LANDSCAPE STRUCTURES, INC.
601 7th STREET SOUTH - P.O. BOX 198
DELAND, MINNESOTA 55328
PH: 1-800-328-0035 FAX: 1-763-972-6091

Date	Previous Drawing #	Initials

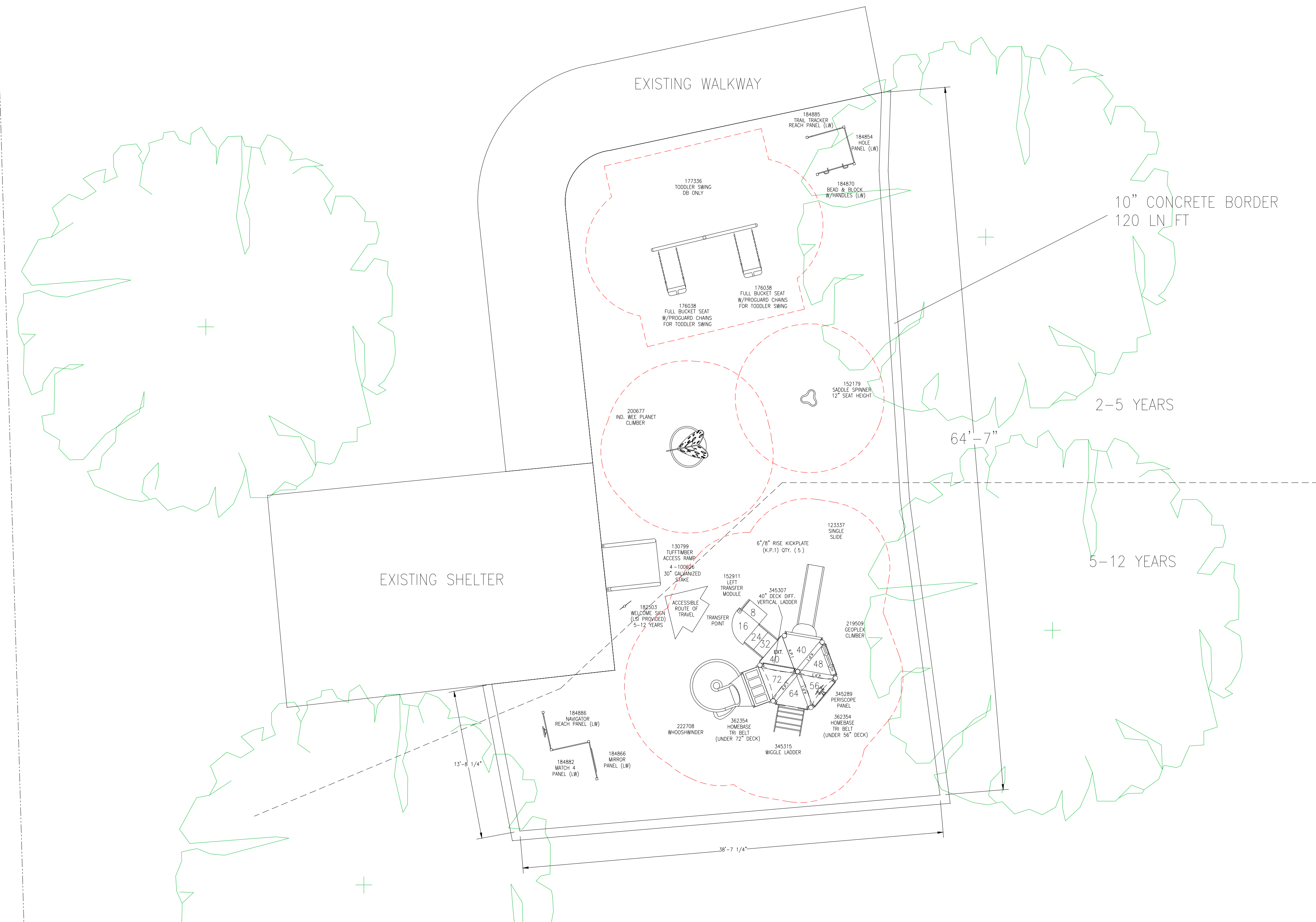

5-12 YEARS **PlayBooster (5-12 years)**
Max Fall Height: 72 inches

2-5 YEARS **Freestanding Play (2-5 years)**
Max Fall Height: 73 inches

TOTAL ELEVATED PLAY COMPONENTS	6		
TOTAL ELEVATED COMPONENTS ACCESSIBLE BY RAMP	0	REQUIRED	0
TOTAL ELEVATED COMPONENTS ACCESSIBLE BY TRANSFER	5	REQUIRED	3
TOTAL ACCESSIBLE GROUND LEVEL COMPONENTS SHOWN	3	REQUIRED	2
TOTAL DIFFERENT TYPES OF GROUND LEVEL COMPONENTS	3	REQUIRED	3

TOTAL ELEVATED PLAY COMPONENTS	0		
TOTAL ELEVATED COMPONENTS ACCESSIBLE BY RAMP	0	REQUIRED	0
TOTAL ELEVATED COMPONENTS ACCESSIBLE BY TRANSFER	0	REQUIRED	0
TOTAL ACCESSIBLE GROUND LEVEL COMPONENTS SHOWN	7	REQUIRED	0
TOTAL DIFFERENT TYPES OF GROUND LEVEL COMPONENTS	6	REQUIRED	6

RED OUTLINE BARRIERS ARE SAFETY USE ZONES - DO NOT ENCR OACH PER ASTM F1487

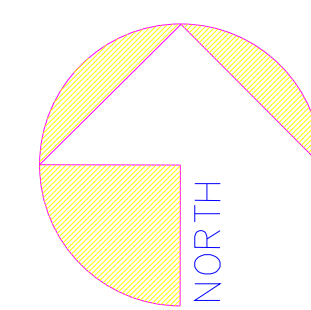
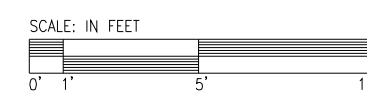

Grandma Foster Park
Option Two
Mount Horeb, WI

Gerber Leisure
Products, Inc.
Kyla Reamon

SYSTEM TYPE:
Multi-system
DRAWING #:
1198497-02-01

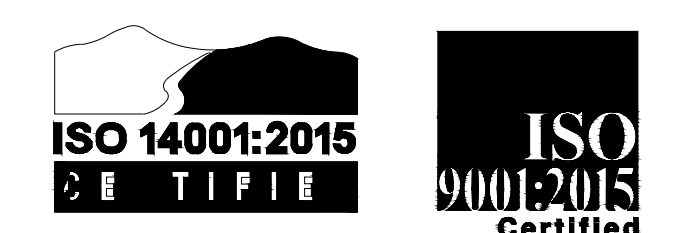

PlayBooster (5-12 years)

* Palette Overridden *



PHASE-1 Direct Bury Aluminum

!! Palette NOT Selected !!

ProShield® Finish

Posts/Arches:  **Limon ***

Clamps/Ball Connectors:  **Lagoon ***

Polyethylene

Slide Hoods/O-Zone®:  **Lagoon ***

Slides/Tunnels/Gliders/E-Pods®:  **Lagoon ***

Permalene®

Primary Permalene:  **Recycled Yellow w/Black *** » Component Colors Below «

Secondary Permalene:  **!! Color NOT Selected !!** » Component Colors Below «

TenderTuff

Barriers/Ladders/Benches:  **Gray ***

Wheels/Rings/Rollers:  **Gray ***

Chains:  **Gray ***

Decks/Step Ladders:  **Gray ***

Vibe® / SteelX®

Primary Panels:  **Yellow ***

Secondary Panels:  **Limon ***

QTY NUMBER DESCRIPTION

Freestanding Play

Learning Wall

1 184882A **Match 4 Panel**

Primary Permalene:  **Recycled Lagoon w/Black=821** «

Secondary Permalene:  **Recycled Yellow w/Black=807** «

1 184866A **Mirror Panel**

Primary Permalene:  **Recycled Yellow w/Black=807**

Secondary Permalene:  **Recycled Lagoon w/Black=821**

1 184886A **Navigator Reach Panel**

Primary Permalene:  **Recycled Yellow w/Black=807**

Wheels/Rings/Rollers:  **Gray=166**

Learning Wall Posts

4 115201A **LW POST DB**

Posts/Arches:  **Limon=317**

Signs

1 182503C **Welcome Sign (LSI Provided) Ages 5-12 years Direct Bury**

Posts/Arches:  **Limon=317**







Surfacing







- 4 100626A **Stake 30" Stl TuffTimber**
- 1 130799A **TuffTimbers Access Wedge**

PlayBooster®











Climbers Other

- 1 219509A **GeoPlex™ Climber 48" Deck**
 - Posts/Arches:  Limon=317
 - Clamps/Ball Connectors:  Lagoon=421
 - Slides/Tunnels/Gliders/E-Pods®:  Lagoon=421
 - Primary Permalene:  Recycled Yellow w/Black=807



Climbers W/Permalene Handholds

- 1 345307C **Vertical Ladder - Panel 40"**
 - Clamps/Ball Connectors:  Lagoon=421
 - Primary Permalene:  Recycled Yellow w/Black=807
- 1 345315E **Wiggle Ladder 64" Dk DB**
 - Clamps/Ball Connectors:  Lagoon=421
 - Primary Permalene:  Recycled Yellow w/Black=807
 - Barriers/Ladders/Benches:  Gray=166
 - Chains:  Gray=166

Decks

- 1 152911B **Curved Transfer Module Left 40" Dk DB**
 - Posts/Arches:  Limon=317
 - Clamps/Ball Connectors:  Lagoon=421
 - Primary Permalene:  Recycled Yellow w/Black=807
 - Barriers/Ladders/Benches:  Gray=166
 - Decks/Step Ladders:  Gray=166
- 4 121948A **Kick Plate 8" Rise**
 - Decks/Step Ladders:  Gray=166
- 5 111231A **Triangular Tenderdeck**
 - Clamps/Ball Connectors:  Lagoon=421
 - Decks/Step Ladders:  Gray=166
- 1 119646A **Triangular Tenderdeck Extension**
 - Clamps/Ball Connectors:  Lagoon=421
 - Decks/Step Ladders:  Gray=166

Enclosures

- 1 345289A **Periscope Panel Above Deck**
 - Clamps/Ball Connectors:  Lagoon=421
 - Primary Permalene:  Recycled Yellow w/Black=807
 - Secondary Panels:  Limon=317



Motion & More Fun

2 362354A **HomeBase Triangle Belt**
 Clamps/Ball Connectors: Lagoon=421

Posts

1 111404E **116" Alum Post DB**
 Posts/Arches: Limon=317

1 111404D **124" Alum Post DB**
 Posts/Arches: Limon=317

1 111404C **132" Alum Post DB**
 Posts/Arches: Limon=317

1 111404B **140" Alum Post DB**
 Posts/Arches: Limon=317

3 111404A **148" Alum Post DB**
 Posts/Arches: Limon=317

Slides

1 123337A **Single Slide 40"Dk DB**
 Posts/Arches: Limon=317
 Clamps/Ball Connectors: Lagoon=421
 Slide Hoods/O-Zone®: Lagoon=421
 Slides/Tunnels/Gliders/E-Pods®: Lagoon=421

1 222708A **WhooshWinder™ Slide 72" Deck/Direct Bury**
 Posts/Arches: Limon=317
 Clamps/Ball Connectors: Lagoon=421
 Slides/Tunnels/Gliders/E-Pods®: Lagoon=421
 Decks/Step Ladders: Gray=166
 Primary Panels: Yellow=007

Freestanding Play (2-5 years)

* Palette Overridden *

PHASE-1 Direct Bury Aluminum

!! Palette NOT Selected !!



ProShield® Finish

Posts/Arches: **Limon ***

Play Components: **Yellow *** » Component Colors Below «

Polyethylene

Slides/Tunnels/Gliders/E-Pods®: **Lagoon ***

Permalene®

Primary Permalene: **Recycled Yellow w/Black *** » Component Colors Below «

Swings

Posts: **Lagoon ***

Beams: **Limon ***

QTY NUMBER DESCRIPTION



Freestanding Play

Climbers

1 200677A **IP Wee Planet Climber DB**

Play Components: Lagoon=421 «

Primary Permalene: Recycled Limon w/Black=817 «

Learning Wall

1 184870B **Bead and Block Panel w/Handles**

Primary Permalene: Recycled Yellow w/Black=807

1 184854A **Hole Panel**

Primary Permalene: Recycled Lagoon w/Black=821 «

1 184885A **Trail Tracker Reach Panel**

Primary Permalene: Recycled Yellow w/Black=807

Learning Wall Posts

2 115201B **LW POST DB**

Posts/Arches: Limon=317

2 115201A **LW POST DB**

Posts/Arches: Limon=317

Motion & More Fun

1 152179A **Saddle Spinner DB 12"Height**

Play Components: Yellow=007

Slides/Tunnels/Gliders/E-Pods®: Lagoon=421

Swings

2 176038G **Full Bucket Seat ProGuard Chains for Toddler Swing**

1 177336A **Toddler Swing Frame DB Only**

Posts: Lagoon=421

Beams: Limon=317



Gerber Leisure Products, INC.

PO Box 42
 Mount Horeb, WI 53572
 Phone: 800-236-7758

Prepared by: Kyla Reamon - kyla@gerberleisure.com

QUOTE

DATE:	7/15/2025
QUOTE Name:	Option Two Traditional
Valid Until:	30 days

Customer
Village of Mount Horeb
Grandma Foster Park 211 W Main S Mt Horeb, WI 53572

DESCRIPTION	QTY	PRICE	AMOUNT
New Landscape Structures play equipment, per attached 2D, 3Ds & Component List	1	48964.6	48,964.60
<i>Discount on equipment, per Kyla</i>	1	-3864.6	-3,864.60
Freight to installer	1	1400	1,400.00
			0.00
Professional installation of above listed equipment	1	16040	16,040.00
<i>Local customer installation discount, per Kyla</i>	1	-2440	-2,440.00
Certified playground wood fiber surfacing, delivered and installed	1	4550	4,550.00
Concrete border per plans - 120 lineal ft. *10" Wide X 4" depth with rebar cable quoted	1	2225	2,225.00
To be completed by Village of Mount Horeb representatives			0.00
Removal and disposal of existing playground equipment Excavation, site prep/leveling per plans Marking of private lines, fire lanes and obtaining permits Site restoration/reseeding Removal of any tree limbs			0.00
<i>The equipment that I have proposed would comply with the current ADA guidelines in and of itself assuming that accessible resilient surfacing is supplied underneath the equipment including under and around the auxiliary ground level equipment, and an access pathway to the area is provided</i>			

TERMS AND CONDITIONS

- All invoices will be sent via QuickBooks. A 3% CC fee will be applied to any CC payments.
- Full payment of materials is due to place the order **\$46,500.00**
- Customer will be billed for applicable installation services and surfacing materials/services at start of work
- Additional agreed upon services will be billed upon completion of the project
- Final payment will be due within 30 days of invoice date, a late fee of 3% per month will be added to any late payments
- Please mail or email signed price quote to the address above
Customer Acceptance (sign below):

x _____
 Print Name:

Subtotal	\$66,875.00
Taxable	\$0.00
Tax rate	0.000%
Tax due	\$0.00
Other	\$0.00
TOTAL Due	\$66,875.00

If you have any questions about this price quote, please contact: Kyla Reamon at 608-437-7037 / kyla@gerberleisure.com

Thank You For Your Business!

Gerber Leisure Products, INC.

PO Box 42
 Mount Horeb, WI 53572
 Phone: 800-236-7758

Prepared by: Kyla Reamon - kyla@gerberleisure.com

QUOTE

DATE:	7/15/2025
QUOTE Name:	Inclusions
Valid Until:	30 days

Customer
Village of Mount Horeb
Grandma Foster Park 211 W Main S Mt Horeb, WI 53572

DESCRIPTION	Includes	Does NOT Include
New Landscape Structures play equipment, per attached 2D, 3Ds & Component List	all equipment listed and shown on corresponding documents	discounts, shipping, installation, surfacing
Discount on equipment, per Kyla	discount from manufacturer LIST pricing of equipment	discounts of any other kind, unless included in this quote
Freight to installer	safe delivery of the listed equipment to a previously agreed upon location, or our installers warehouse for storage	unloading of freight
Professional installation of above listed equipment	digging footing holes, assembly of equipment, concrete for footings, project management, calling diggers, coordination of materials	excavation, site prep/leveling, surfacing, installation of surfacing, private lines marking or responsibility
Discount for local customer, per Kyla	discount from installation pricing of the playground equipment	discounts of any other kind, unless included in this quote
Certified playground wood fiber	materials, shipping, installation	fabric, drain tile
To be completed by Village of Mount Horeb representatives		
Removal and disposal of existing playground equipment		
Excavation, site prep/leveling per plans		
Marking of private lines, fire lanes and obtaining permits		
Site restoration/reseeding		
Removal of any tree limbs in the playspace		
<p><i>The equipment that I have proposed would comply with the current ADA guidelines in and of itself assuming that accessible resilient surfacing is supplied underneath the equipment including under and around the auxiliary ground level equipment, and an access pathway to the area is provided</i></p>		

TERMS AND CONDITIONS

1. Full payment on materials is due to place the order.
 2. Customer will be billed for applicable installation services at start of work
 3. Additional services (surfacing) will be billed upon completion of the project
 4. Payment will be due within 30 days of invoice date
 5. Please mail or email signed price quote to the address above
- Customer Acceptance (sign below):

x _____
 Print Name:

If you have any questions about this price quote, please contact: Kyla Reamon at 608-437-7037 / kyla@gerberleisure.com

Thank You For Your Business!

Option Two Component List

Date:07/14/2025

Rep Organization: Gerber Leisure
Products, Inc.

Quote No: Opt2

By:KLP

Contact Person: Kyla Reamon

Project Title: Grandma Foster Park

Location: Mount Horeb, WI

PlayBooster (5-12 years)						
PHASE-1 Direct Bury Aluminum			UNIT		TOTAL	
QTY	NO.	DESCRIPTION	WEIGHT (lb)	PRICE (US \$)	WEIGHT (lb)	PRICE (2025)
PlayBooster®						
Climbers Other						
1	219509A	GeoPlex Climber 48"Dk			64.0	1,280.00
Climbers W/Permalene Handholds						
1	345307C	Vertical Ladder - Panel 40"			57.0	1,445.00
1	345315E	Wiggle Ladder 64"Dk DB			58.0	1,155.00
Decks						
1	152911B	Curved Transfer Module Left 40"Dk DB			240.0	3,695.00
4	121948A	Kick Plate 8"Rise	13.0	150.00	52.0	600.00
5	111231A	Triangular Tenderdeck	62.0	1,060.00	310.0	5,300.00
1	119646A	Tri-Deck Extension			51.0	1,030.00
Enclosures						
1	345289A	Periscope Panel Above Deck			63.0	2,175.00
Motion & More Fun						
2	362354A	HomeBase Tri Belt	16.0	1,555.00	32.0	3,110.00
Posts						
1	111404E	116"Alum Post DB			29.0	415.00
1	111404D	124"Alum Post DB			30.0	475.00
1	111404C	132"Alum Post DB			31.0	495.00
1	111404B	140"Alum Post DB			34.0	500.00
3	111404A	148"Alum Post DB	36.0	530.00	108.0	1,590.00
Slides						
1	123337A	Single Slide 40"Dk DB			94.0	2,090.00
1	222708A	WhooshWinder Slide 72"Dk DB ¹			346.0	6,760.00
Freestanding Play						
Learning Wall						
1	184882A	Match 4 Panel			35.0	1,245.00
1	184866A	Mirror Panel			41.0	1,325.00
1	184886A	Navigator Reach Panel			26.0	835.00
Learning Wall Posts						
4	115201A	LW Post 10"Panel DB	14.0	345.00	56.0	1,380.00
Signs						
1	182503C	Welcome Sign (LSI Provided) Ages 5-12 years Direct Bury			24.0	0.00

Option Two Component List

Date:07/14/2025

Rep Organization: Gerber Leisure
Products, Inc.

Quote No: Opt2

By:KLP

Contact Person: Kyla Reamon

Project Title: Grandma Foster Park

Location: Mount Horeb, WI

PlayBooster (5-12 years)						
PHASE-1 Direct Bury Aluminum			UNIT		TOTAL	
QTY	NO.	DESCRIPTION	WEIGHT (lb)	PRICE (US \$)	WEIGHT (lb)	PRICE (2025)
Surfacing						
4	100626A	30" Galvanized Stake	4.0	18.65	16.0	74.60
1	130799A	TuffTimbers Access Wedge			90.0	1,160.00

Freestanding Play (2-5 years)						
PHASE-1 Direct Bury Aluminum			UNIT		TOTAL	
QTY	NO.	DESCRIPTION	WEIGHT (lb)	PRICE (US \$)	WEIGHT (lb)	PRICE (2025)
Freestanding Play Climbers						
1	200677A	Wee Planet Climber DB			127.0	3,285.00
Learning Wall						
1	184870B	Bead and Block Panel w/Handles			64.0	1,585.00
1	184854A	Hole Panel			23.0	625.00
1	184885A	Trail Tracker Reach Panel			14.0	585.00
Learning Wall Posts						
2	115201B	LW Post 1"Panel DB	13.0	340.00	26.0	680.00
2	115201A	LW Post 10"Panel DB	14.0	345.00	28.0	690.00
Motion & More Fun						
1	152179A	Saddle Spinner DB 12"Height			40.0	990.00
Swings						
2	176038G	Full Bucket Seat ProGuard Chains for Toddler Swing	11.0	460.00	22.0	920.00
1	177336A	Toddler Swing Frame DB Only			136.0	1,470.00

SUMMARY				WEIGHT (lb)	PRICE (2025)
PlayBooster (5-12 years) PHASE-1				1,887.0	38,134.60
Total Safety Zone Area = 1172 sq. ft.					
Freestanding Play (2-5 years) PHASE-1				480.0	10,830.00
Total Safety Zone Area = 1172 sq. ft.					

Option Two Component List

Date:07/14/2025

Rep Organization: Gerber Leisure
Products, Inc.

Quote No: Opt2

By:KLP

Contact Person: Kyla Reamon

Project Title: Grandma Foster Park

Location: Mount Horeb, WI

ALL PHASES	PlayBooster®	1,599.0	32,115.00
	Freestanding Play	768.0	16,849.60
	Total	2,367.0	48,964.60



AGENDA ITEM REPORT

MEETING DATE

July 22, 2025

PREPARED BY

AGENDA ITEM # 5.e

Katie Hartman - Request for spots in Village Parks for yard in a yard program

BACKGROUND

RECOMMENDATION

ATTACHMENTS

1. A Yard in Every Yard

A Yard in Every Yard
A Pot in Every Spot

Mount Horeb Green Team

Objective: To establish a pollinator corridor through the village of Mount Horeb across both village-owned and residential green spaces via small patches of native pollinator-friendly plantings.

Process: Roll out a village-wide sow-along project where everyone moves through the stages of planting their “Yards” at the same time. Ideally, this would start with at least 8 weeks of black plastic tarping starting in August, seed distribution September and October, planting of seeds around Halloween / early November, and then a city-wide posting of seeds sprouting in spring.

Timeline: Could be started this year – that might be pushing it with messaging / site prep / rollout. We could instead do a site prep / sowing this year for selected village lands and volunteer houses to collect visuals / best practices for use in messaging with a summer 2026 launch.

- May-August: Messaging around Mount Horeb about the project
 - Get resident signups – name and email address for everyone. Physical address if they would like to be added to the map.
 - Messaging about why this is important and how easy it would be to participate.
 - Messaging about not spraying herbicides in that area in the fall.
 - Start packaging seeds
- July-end of October:
 - Distribute a package with instructions, site selection, value of pollinators, a clear or black plastic bag (for tarping), a packet of seeds, and messaging about the Green Team.
 - Messaging about perennials vs annuals. Some plants will not flower the first year.
 - Residents choose and tarp their square “yard” in their lawns.
- End of October / early November:
 - Seeding day. Everyone removes their tarps, pulls up any residual weeds or grass, rakes the soil, and surface sows seeds.
 - People who want to use pots add soil and sow at this time. Make sure to message not to use ceramic pots as they will break in the winter.
- Spring: Show us your seedlings!
 - Start posting weekly updates of what is sprouting. Give visual instructions on what seedlings should look like and what to remove (weeds).
 - Remind residents to cover their “yard” when spraying weed-n-feed / any herbicides or pesticides.
- Summer: Show us your flowers!
 - Post weekly visuals of flowers and pollinators around town. Post map of “yards”
 - Encourage next group of signups

Seed choices: Pollinator Palooza Prairie Moon Nursery + small selection of annuals that will absolutely flower the first spring.

for Medium-Wet to Medium-Dry Soils & Full to Partial Sun *Pollinator-Palooza [pol-uh-neyt-ohr-pah-looz-ah] noun. def: 1. an all-out crazy party for bees, butterflies and other pollinators; 2. A field you visit with a mob of fellow pollinators to pollinate like there's no tomorrow.*

We are offering this seed mix in cooperation with the ["Bring Back the Pollinators" campaign](#) of the non-profit [Xerces Society](#). Pollinators are critical to human food crops yet our practices result in habitat loss, environmental toxins and monocultural cropping that compound stressors on them, threatening their, and our, survival. To counter this trend and introduce more pollinator-friendly plant diversity, this uniquely diverse, 100% North American native mix includes species that produce not only nectar but the habitat that pollinators require for survival.

Designed for full-sun to partial-shade sites with medium soils, this mixed-height mix boasts grasses and most wildflowers at 3', with some flowers reaching 6' at full bloom. Bloom times progress spring through fall. Our Pollinator-Palooza Seed Mix moves beyond more common pollinator mixes by offering plants that appeal to a broad array of pollinating insects. Included in the 45 species are some not commonly available like [Late Figwort](#) and [Hairy Mountain Mint](#). Although some of the native plants in this seed mix have ranges that extend beyond zones 3-7, the majority will do best in this zone range. For more detailed information please see the RANGE MAP for each species. View the complete species list, including % by weight, under COMPONENTS.

Pollinator-Palooza© Seed Mix

by Prairie Moon® Nursery

6.53 lbs per acre | 114 Seeds per sq/ft

[\(FILTER PLANTS IN THIS SEED MIX\)](#)

WILDFLOWERS

Botanical Name (Common Name)	% by wt.
Agastache foeniculum (Anise Hyssop)	0.96
Allium cernuum (Nodding Onion)	0.96
Asclepias incarnata (Rose Milkweed)	1.91
Asclepias syriaca (Common Milkweed)	1.43
Asclepias tuberosa (Butterfly Weed)	0.96
Asclepias verticillata (Whorled Milkweed)	1.91
Baptisia alba (White Wild Indigo)	0.48
Chamaecrista fasciculata (Partridge Pea)	4.78
Coreopsis lanceolata (Lance-leaf Coreopsis)	2.87
Dalea purpurea (Purple Prairie Clover)	2.87
Echinacea pallida (Pale Purple Coneflower)	2.87
Echinacea purpurea (Purple Coneflower)	1.91
Eryngium yuccifolium (Rattlesnake Master)	1.91
Gaura biennis (Biennial Gaura)	0.48
Helianthus pauciflorus (Showy Sunflower)	0.24
Lespedeza capitata (Round-headed Bush Clover)	0.48
Liatris ligulistylis (Meadow Blazing Star)	1.91
Liatris pycnostachya (Prairie Blazing Star)	1.91
Lobelia siphilitica (Great Blue Lobelia)	0.96
Monarda fistulosa (Wild Bergamot)	0.48
Oligoneuron rigidum (Stiff Goldenrod)	0.96
Parthenium integrifolium (Wild Quinine)	0.24
Penstemon digitalis (Foxglove Beardtongue)	0.96
Pycnanthemum verticillatum var. pilosum (Hairy Mountain Mint)	0.51
Pycnanthemum virginianum (Mountain Mint)	1.02
Ratibida pinnata (Yellow Coneflower)	0.48
Rudbeckia hirta (Black-eyed Susan)	5.74
Rudbeckia triloba (Brown-eyed Susan)	0.24
Scrophularia lanceolata (Early Figwort)	0.60

Senna hebecarpa (Wild Senna)	1.02
Solidago nemoralis (Old Field Goldenrod)	0.48
Solidago speciosa (Showy Goldenrod)	0.48
Symphyotrichum laeve (Smooth Blue Aster)	1.43
Tradescantia ohioensis (Ohio Spiderwort)	2.87
Verbena hastata (Blue Vervain)	0.96
Veronicastrum virginicum (Culver's Root)	0.48
Zizia aurea (Golden Alexanders)	2.87
Total of WILDFLOWERS:	53.61 %
TREES, SHRUBS & VINES	
Botanical Name (Common Name)	% by wt.
Amorpha canescens (Lead Plant)	0.96
Hypericum prolificum (Shrubby St. John's Wort)	0.96
Totals of TREES, SHRUBS & VINES:	1.91 %
GRASSES, SEDGES & RUSHES	
Botanical Name (Common Name)	% by wt.
Bouteloua curtipendula (Side-oats Grama)	15.30
Elymus canadensis (Canada Wild Rye)	6.70
Juncus tenuis (Path Rush)	0.96
Koeleria macrantha (June Grass)	2.39
Schizachyrium scoparium (Little Bluestem)	15.30
Sporobolus compositus (Rough Dropseed)	2.87
Sporobolus heterolepis (Prairie Dropseed)	0.96
Totals of GRASSES, SEDGES & RUSHES:	44.48 %



AGENDA ITEM REPORT

MEETING DATE

July 22, 2025

PREPARED BY

AGENDA ITEM # 5.f

Capital Budget Requests

BACKGROUND

RECOMMENDATION

ATTACHMENTS

1. Grundahl.Foster master plan powerpoint
2. capital requests PRF 26
3. capital improvement plan PARKS 26.30



VILLAGE BOARD MEETING

GRANDMA FOSTER + GRUNDAHL PARK

October 4th, 2023



Grandma Foster Park

CHARACTER IMAGERY

Village of Mount Horeb, Wisconsin
March 27th, 2023



AMENITIES

Open-Air Shelter



Wayfinding Sign



Grand Entrance Stairs



ACTIVITIES

Troll Play Feature (Earthscape)



Sensory Play



Wayfinding - Troll Footprints



Traditional Play



Plaza - Pavement Pattern



Plantings



EXPERIENCE

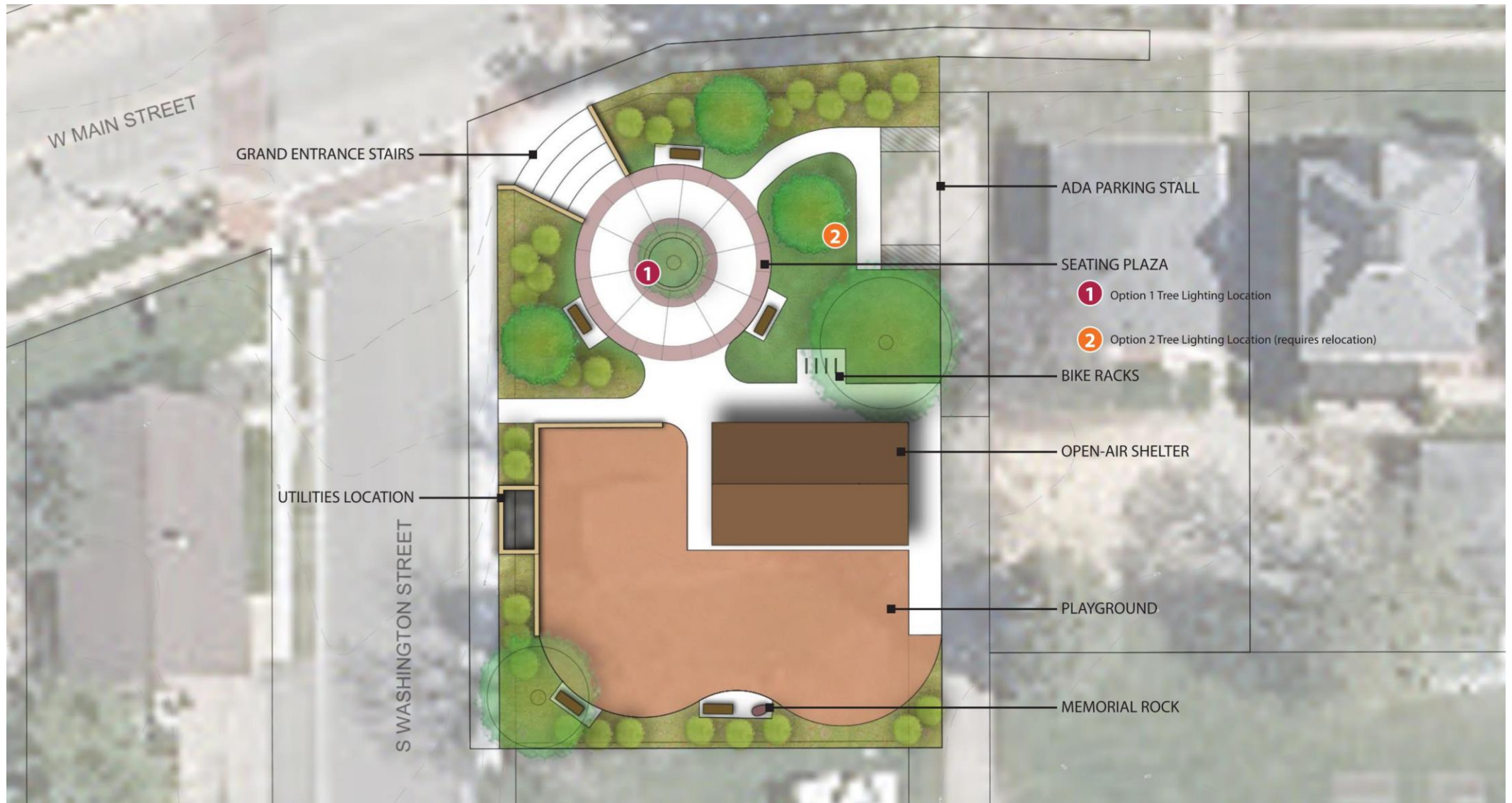

Master Plan

LEGEND



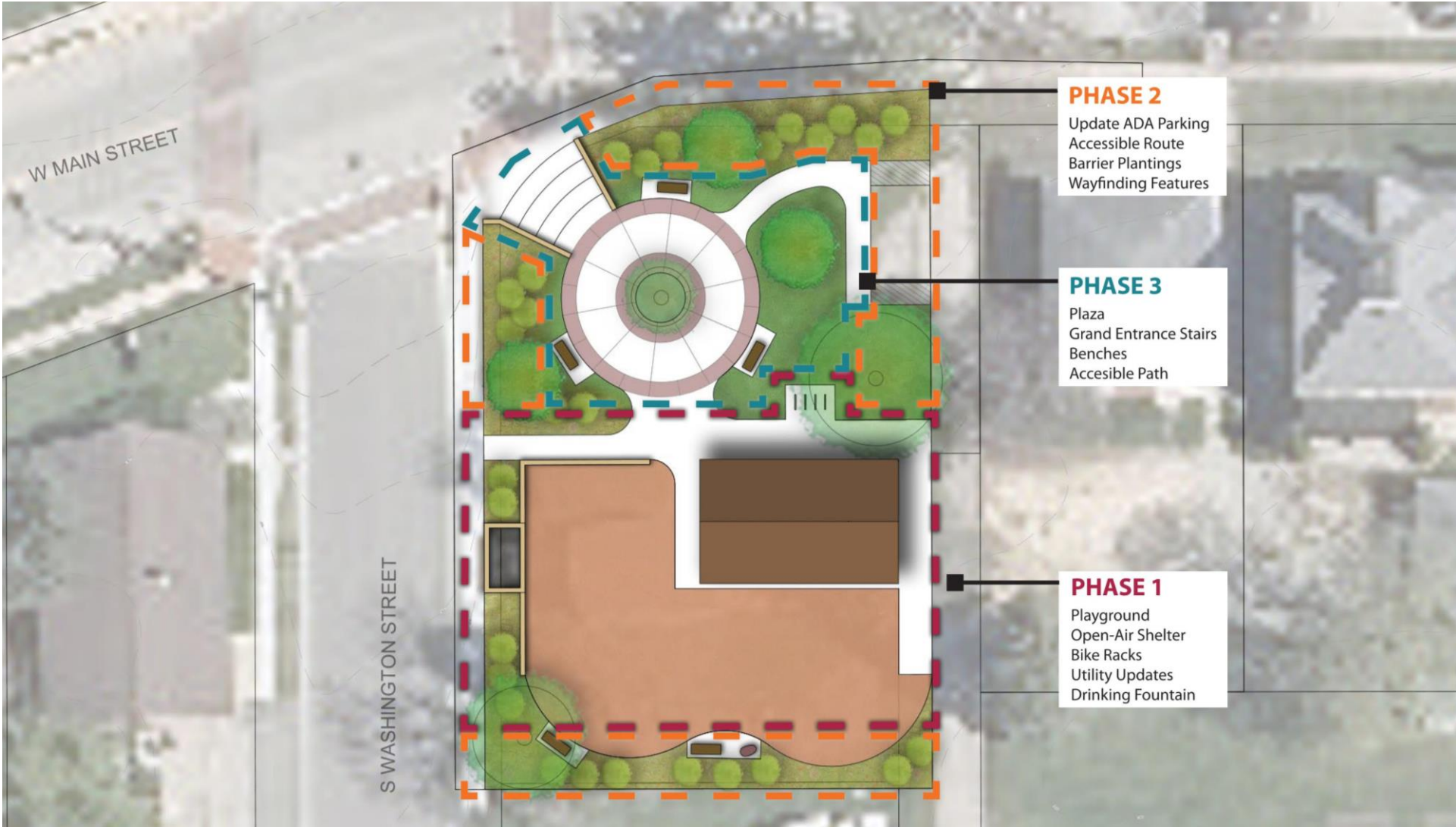

Phase 1: \$360,000

Phase 2: \$37,000

Phase 3: \$119,000

Phasing Plan

TO FRONT STREET
↓

STRUCTURES + SPACE

Multi-Use Event and Programming Space



Wednesday Night Live Concert Series



ACTIVITIES

Pickleball Courts



Basketball Courts



3-Season Park Shelter



Native Plantings



Playground



Octagonal Shelter (Existing)



Sledding Hill



Batting Cages



PLACES

Master Plan

LEGEND



Proposed Tree



Existing Tree

- 1** Maintain Ex. Parking, New Sidewalk (25 stalls)
 - 2** Announcer Booth Addition
 - 3** Dugout Improvements
 - 4** Field Improvements
 - 5** Batting Cages (2)
 - 6** Pickleball Courts (2)
 - 7** Stormwater Area
 - 8** Basketball Court (1)
 - 9** Playground (5,800 SF)
 - 10** Maintain Existing Shelter
 - 11** Maintain Ex. Parking (56 stalls - 2 ADA)
 - 12** Expand Parking (19 stalls - 1 ADA)
 - 13** Multi-Use Event Building
 - 14** New Shelter, Restrooms and Kitchen
 - 15** Native Plantings
 - 16** Regrade for Open Field Space
 - 17** Maintain Community Stage
 - 18** Angled Parking (11 stalls - 1 ADA)
- Total Cost:** \$8,993,000
- Inflation Total:** \$11,906,725
- Items >\$250,000
- Multi-Use Event Building \$450,000
 - New Restroom/Kitchen/Shelter Facility \$650,000
 - Accessible Pathways - \$355,000



PHASE 1

LEGEND



Proposed Tree



Existing Tree

PHASE 1

- Playground 1
- Basketball Court 2
- Existing Shelter Structural Analysis (Octagonal) 3
- Baseball Improvements Phase #1 4

PHASE 2

- Batting Cages
- Baseball Improvements Phase #2
- Accessible Routes and Parking

PHASE 3

- Community Stage Updates
- Existing Shelter Updates (Octagonal)
- Pickleball Courts
- Restroom/Kitchen/Shelter Facility

PHASE 4

- Multi-Purpose Building
- Field Space Renovation



Phase 1: \$975,450 (2025)

Total: \$11,906,725

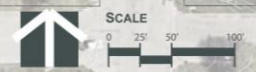

PHASE 2

LEGEND



Proposed Tree



Existing Tree

PHASE 1

- Playground
- Basketball Court
- Existing Shelter Structural Analysis (Octagonal)
- Baseball Improvements Phase #1

PHASE 2

- Batting Cages 1
- Baseball Improvements Phase #2 2
- Accessible Routes 3
- Parking Additions 4

PHASE 3

- Community Stage Updates
- Existing Shelter Updates (Octagonal)
- Pickleball Courts
- Restroom/Kitchen/Shelter Facility

PHASE 4

- Multi-Purpose Building
- Field Space Renovation

Phase 2: \$1,460,800 (2027)

Total: \$11,906,725



Phase 3

LEGEND



Proposed Tree

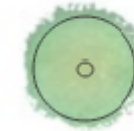

Existing Tree

PHASE 1

- Playground
- Basketball Court
- Existing Shelter Structural Analysis (Octagonal)
- Baseball Improvements Phase #1

PHASE 2

- Batting Cages
- Baseball Improvements Phase #2
- Accessible Routes and Parking

PHASE 3

- Community Stage Updates ①
- Existing Shelter Updates (Octagonal) ②
- Pickleball Courts ③
- Restroom/Kitchen/Shelter Facility ④

PHASE 4

- Multi-Purpose Building
- Field Space Renovation



Phase 3: \$1,552,175
(2030)

Total: \$11,906,725

Phase 4

LEGEND



Proposed Tree

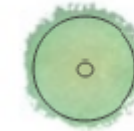

Existing Tree

PHASE 1

- Playground
- Basketball Court
- Existing Shelter Structural Analysis (Octagonal)
- Baseball Improvements Phase #1

PHASE 2

- Batting Cages
- Baseball Improvements Phase #2
- Accessible Routes and Parking

PHASE 3

- Community Stage Updates
- Existing Shelter Updates (Octagonal)
- Pickleball Courts
- Restroom/Kitchen/Shelter Facility

PHASE 4

- Multi-Purpose Building ①
- Field Space Renovation ②
- Native Plantings ③



Phase 4: \$7,918,300 (2035)

Total: \$11,906,725



Discussion - Questions – Comments

GRANDMA FOSTER + GRUNDAHL PARK

October 4th, 2023



ESTIMATE YEAR:					2023
ITEM NO.	DESCRIPTION	QTY.	UNIT	UNIT PRICE	TOTAL PRICE
PHASE 1					
1	Open Prefabricated Park Shelter (25x40)	1	LS	\$65,000	\$65,000
2	6' Benches	2	EA	\$2,000	\$4,000
3	Bike Racks	4	EA	\$700	\$2,800
4	Trash Cans	2	EA	\$1,500	\$3,000
5	Drinking Fountain	1	EA	\$9,000	\$9,000
6	6' Picnic Tables	3	EA	\$2,500	\$7,500
7	Concrete Park Path - 5' + Pads (est.)	1,200	SF	\$10	\$12,000
8	Playground Area (3,200 SF)	1	LS	\$150,000	\$150,000
9	Earthwork (est.)	1	LS	\$4,000	\$4,000
10	Site Restoration - Lawn (est.)	100	SY	\$4	\$400
11	Landscaping (est.)	1,000	SF	\$8	\$8,000
12	Shelter Electrical Service (est.)	1	LS	\$5,000	\$5,000
13	Water Service (est.)	1	LS	\$3,000	\$3,000
14	Stormwater (est.)	1	LS	\$5,000	\$5,000
15	Erosion Control	1	LS	\$2,500	\$2,500
16	General Conditions/Mobilization (8%)	1	LS	\$12,000	\$12,000
PHASE 1 CONSTRUCTION SUBTOTAL					\$294,000
Contingency 10%					\$30,000
Design Engineering & Bidding 6%					\$18,000
Construction Administration 6%					\$18,000
PHASE 1 TOTAL					\$360,000

GRANDMA FOSTER PARK COSTS

PHASE 2					
5	Earthwork (est.)	1	LS	\$3,000	\$3,000
6	Site Restoration - Lawn (est.)	60	SY	\$4	\$240
7	Landscaping (est.)	1,000	SF	\$8	\$8,000
8	Trees	3	EA	\$500	\$1,500
9	Park Sign	1	LS	\$5,000	\$5,000
10	Stormwater (est.)	1	LS	\$2,000	\$2,000
11	Erosion Control	1	LS	\$2,000	\$2,000
12	General Conditions/Mobilization (8%)	1	LS	\$8,000	\$8,000
PHASE 2 CONSTRUCTION SUBTOTAL					\$30,000
Contingency 10%					\$3,000
Design Engineering & Bidding 6%					\$2,000
Construction Administration 6%					\$2,000
PHASE 2 TOTAL					\$37,000
PHASE 3					
1	6' Benches	3	EA	\$2,000	\$6,000
2	Concrete Park Path - 5' + Pads (est.)	1,800	SF	\$10	\$18,000
3	ADA Parking	1	LS	\$3,500	\$3,500
4	Grand Entrance Stairs	1	LS	\$50,000	\$50,000
5	Earthwork (est.)	1	LS	\$3,000	\$3,000
6	Site Restoration - Lawn (est.)	60	SY	\$4	\$240
7	Landscaping (est.)	70	SF	\$8	\$560
10	Stormwater (est.)	1	LS	\$3,000	\$3,000
11	Erosion Control	1	LS	\$500	\$500
12	General Conditions/Mobilization (8%)	1	LS	\$12,000	\$12,000
PHASE 3 CONSTRUCTION SUBTOTAL					\$97,000
Contingency 10%					\$10,000
Design Engineering & Bidding 6%					\$6,000
Construction Administration 6%					\$6,000
PHASE 3 TOTAL					\$119,000
PROJECT TOTAL COST:					\$516,000

ESTIMATE YEAR:					2023
ITEM NO.	DESCRIPTION	QTY.	UNIT	UNIT PRICE	TOTAL PRICE
1	Improve/Addition to Existing Concessions	1	LS	\$150,000	\$150,000
2	6' Benches	5	EA	\$2,000	\$10,000
3	Trash Cans	6	EA	\$1,500	\$9,000
4	Bike Racks	5	EA	\$500	\$2,500
5	Concrete Park Path - 5' + 10' + Pads (est.)	5,000	SF	\$10	\$50,000
6	Asphalt Path - 10'	1,500	SF	\$8	\$12,000
7	Playground Area (5840 SF)	1	LS	\$200,000	\$200,000
8	Basketball Court	1	LS	\$90,000	\$90,000
9	Improve Existing Baseball Field	1	LS	\$90,000	\$90,000
10	Site Lighting (light poles)	3	EA	\$5,000	\$15,000
11	Earthwork (est.)	1	LS	\$20,000	\$20,000
12	Site Restoration - Lawn	1,000	SY	\$3	\$3,000
13	Stormwater Areas	1,500	SF	\$8	\$12,000
14	Upgrade Electrical Service (est.)	1	LS	\$7,000	\$7,000
15	Storm Sewer (est.)	1	LS	\$15,000	\$15,000
16	Erosion Control	1	LS	\$7,000	\$7,000
17	General Conditions/Mobilization (8%)	1	LS	\$56,000	\$56,000
CONSTRUCTION SUBTOTAL					\$749,000
Contingency 10%					\$75,000
Design Engineering & Bidding 6%					\$45,000
Structural Assessment of Existing Shelter LS					\$15,000
Construction Administration 6%					\$45,000
PHASE 1 TOTAL COST:					\$929,000
					2025 \$975,450

ESTIMATE YEAR:					2023
ITEM NO.	DESCRIPTION	QTY.	UNIT	UNIT PRICE	TOTAL PRICE
1	Trash Cans	2	EA	\$1,500	\$3,000
2	Bike Racks	10	EA	\$500	\$5,000
3	Drinking Fountain	1	EA	\$9,000	\$9,000
4	Concrete Park Path - 5' + 10' + Pads (est.)	26,000	SF	\$10	\$260,000
5	Asphalt Path - 10'	9,500	SF	\$8	\$76,000
6	New Asphalt Parking (# stalls)	12,000	SF	\$8	\$96,000
7	Improved Asphalt Parking	27,500	SF	\$8	\$220,000
8	Improve Existing Baseball Field	1	LS	\$60,000	\$60,000
9	Ballfield Lighting (6 poles)	1	LS	\$180,000	\$180,000
10	Site Lighting (light poles)	5	EA	\$5,000	\$25,000
11	Earthwork (est.)	1	LS	\$10,000	\$10,000
12	Landscaping (est.)	50	SF	\$8	\$400
13	Site Restoration - Lawn	800	SY	\$3	\$2,400
14	Stormwater Areas	3,300	SF	\$8	\$26,400
15	Trees	11	EA	\$500	\$5,500
16	Park Sign	1	LS	\$5,000	\$5,000
17	Water Service (est.)	1	LS	\$3,000	\$3,000
18	Storm Sewer (est.)	1	LS	\$15,000	\$15,000
19	Erosion Control	1	LS	\$5,000	\$5,000
20	General Conditions/Mobilization (8%)	1	LS	\$80,000	\$80,000
CONSTRUCTION SUBTOTAL					\$1,087,000
Contingency 10%					\$109,000
Design Engineering & Bidding 6%					\$66,000
Construction Administration 6%					\$66,000
PHASE 2 TOTAL COST:					\$1,328,000
					2027 \$1,460,800

GRUNDAHL PARK COSTS

ESTIMATE YEAR:				2023	
ITEM NO.	DESCRIPTION	QTY.	UNIT	UNIT PRICE	TOTAL PRICE
1	New Restroom/Kitchen/Shelter Facility (4,500 SF)	1	LS	\$650,000	\$650,000
2	Existing Octagonal Shelter Improvements	1	LS	\$100,000	\$100,000
3	6' Benches	5	EA	\$2,000	\$10,000
4	Trash Cans	2	EA	\$1,500	\$3,000
5	Bike Racks	5	EA	\$500	\$2,500
6	6' Picnic Tables	4	EA	\$2,000	\$8,000
7	Drinking Fountain	1	EA	\$9,000	\$9,000
8	Concrete Park Path - 5' + 10' + Pads (est.)	3,500	SF	\$10	\$35,000
9	Pickleball Courts	2	EA	\$60,000	\$120,000
9	Site Lighting (light poles)	2	EA	\$5,000	\$10,000
10	Earthwork (est.)	1	LS	\$10,000	\$10,000
11	Landscaping (est.)	100	SF	\$8	\$800
12	Site Restoration - Lawn	500	SY	\$3	\$1,500
13	Stormwater Areas	500	SF	\$8	\$4,000
14	Trees	9	EA	\$500	\$4,500
15	Upgrade Electrical Service (est.)	1	LS	\$9,000	\$9,000
16	Water Service (est.)	1	LS	\$4,000	\$4,000
17	Sanitary Sewer (est.)	1	LS	\$5,000	\$5,000
18	Storm Sewer (est.)	1	LS	\$10,000	\$10,000
19	Erosion Control	1	LS	\$5,000	\$5,000
20	General Conditions/Mobilization (8%)	1	LS	\$80,000	\$80,000
CONSTRUCTION SUBTOTAL					\$1,082,000
Contingency 10%					\$109,000
Design Engineering & Bidding 6%					\$65,000
Construction Administration 6%					\$65,000
PHASE 3 TOTAL COST:					\$1,321,000
					2030
					\$1,552,175

ESTIMATE YEAR:				2023	
ITEM NO.	DESCRIPTION	QTY.	UNIT	UNIT PRICE	TOTAL PRICE
1	Multi-Use Event Building (20,000 SF)	1	LS	\$4,500,000	\$4,500,000
2	Drinking Fountain	1	EA	\$9,000	\$9,000
3	Concrete Park Path - 5' + 10' + Pads (est.)	1,000	SF	\$10	\$10,000
4	Earthwork (est.)	1	LS	\$40,000	\$40,000
5	Landscaping (est.)	450	SF	\$8	\$3,600
6	Site Restoration - Lawn	2,075	SY	\$3	\$6,225
7	Native Areas - seeding and maintenance (est.)	4,000	SY	\$4	\$16,000
8	Stormwater Areas	500	SF	\$8	\$4,000
9	Site Lighting (light poles)	1	EA	\$5,000	\$5,000
9	Upgrade Electrical Service (est.)	1	LS	\$9,000	\$9,000
10	Water Service (est.)	1	LS	\$3,000	\$3,000
11	Sanitary Sewer (est.)	1	LS	\$10,000	\$10,000
12	Storm Sewer (est.)	1	LS	\$10,000	\$10,000
13	Erosion Control	1	LS	\$8,000	\$8,000
14	General Conditions/Mobilization (8%)	1	LS	\$357,000	\$357,000
CONSTRUCTION SUBTOTAL					\$4,991,000
Contingency 10%					\$500,000
Design Engineering & Bidding 6%					\$300,000
Construction Administration 6%					\$300,000
PHASE 4 TOTAL COST:					\$6,091,000
					2035
					\$7,918,300

Phased Costs with Inflation (2.5% per year)			
Phase 1	2025	\$	975,450
Phase 2	2027	\$	1,460,800
Phase 3	2030	\$	1,552,175
Phase 4	2035	\$	7,918,300
TOTAL COST OF ALL PHASES WITH INFLATION			\$ 11,906,725

GRUNDAHL PARK COSTS



Village of Mount Horeb

Public Services Department

138 E Main St
Mount Horeb, WI 53572
Phone (608) 437-3351/Fax (608) 437-3190
www.mounthorebwi.info

2026 CAPITAL BUDGET REQUESTS **PARKS, REC AND FORESTRY COMMISSION**

PLAYGROUND EQUIPMENT REPLACEMENT – GRANDMA FOSTER PARK	\$74,000
The existing playground equipment is 31 years old and is in need of replacement. The plan is to expand the area of the playground to the south and southwest to allow for some swings and slightly more or larger equipment.	
PAINT WADING POOL, PLUNGE POOL AND MUSHROOM FEATURE	\$12,000
We paint these two pools approximately every four years.	
WALTZ PARK SHELTER ROOF (ASPHALT SHINGLES)	\$15,000
The original shingles will be 28 years old and should be replaced. The skylights look like they are in good condition.	
WALTZ PARK SIGN REPLACEMENT	\$5,000
The park sign in front of the restrooms should be replaced. We can discuss designs if the budget item is approved.	
LIBERTY PARK POWER WASHING AND STAINING	\$5,000
All wood including the roof decking, soffit and fascia is in need of washing and staining.	

**Mount Horeb Public Services Dept.
Capital Improvement Plan-PARKS/FORESTRY
2026-2030**

ITEM	2025	2026	2027	2028	2029	2030
Access control for Grundahl, Liberty and Sunrise	11,000					
Timed restroom locks for Grundahl and Liberty	4,700					
Sunrise Park ball field improvements	20,000					
2018 John Deere 1580 mower	35,000					
2015 Ford F-250 Pickup	60,000					
Update Comp. Outdoor Recreation Plan	26,000					
Replace Grundahl Park ball diamond lights	190,000					
Replace 30-year old utility trailer	6,000					
Playground equipment replacement-Grundahl	200,000					
Replace 2006 fertilizer spreader	6,000					
Playground equipment replacement-Himsel			100,000			
Playground equipment replacement-Lions				100,000		
Replace 2019 Kubota utility vehicle					??	
Playground equipment replacement-Foster Park		74,000				
Pool painting - Wading/Plunge pools		12,000				
Liberty shelter - prep and restain all wood		5,000				
Waltz Park - Replace park sign		5,000				
Waltz shelter - replace roof		15,000				
Purchase wide area mower (11')			60,000			
Aquatic Center Bathhouse - replace roof			25,000			
Grundahl Park ball diamond shelter/storage						
Grundahl Park ball diamond improvements						
TOTALS	558,700	111,000	185,000	100,000		



Village of Mount Horeb

Recreation Department

105 North Grove Street
Mount Horeb, WI 53572

Phone (608) 437-3400 | Email: jill.dudley@mounthorebwi.info

PARKS, RECREATION, AND FORESTRY COMMISSION

July 22, 2025

Recreation Director's Report

1. June Program Numbers:

<u>Program Name</u>	<u>2024 Participants</u>	<u>2023 Participants</u>
Babysitting Class	15	13
T-Ball	108	116
Martial Arts (Summer #1)	12	N/A (didn't run in the summer)
Water Aerobics (NEW)	11	N/A (new program)
Taekwondo (Summer #1)	21	13
Fencing Camp	13	13
Speedball Camp	52	52
Viking Soccer Camps	77	75
Gymnastics (Level 1 & 2)	65	64
Little Star Kickers (Summer)	24	N/A (didn't run in the summer)
Yoga (Mind & Body)	8	N/A (new program)
Grass Volleyball League	10 teams	16 teams
Kids Camp (Session #1)	18	23
Toddler Yoga (Session #1)	7	N/A (new program)
Tree Climbing	27	25
Swim Lessons (Session #1)	123	129
Disc Golf	12	9
Coing for Middle Schoolers	12	N/A (new program)
Kids Yoga (Session #1)	6	N/A (didn't run in the summer)
Youth Track	135	130
Little Trolls Yoga	7	23
Ultimate Frisbee Camp	17	20
YEL Rocketry Camp	9	16
Little Trolls Volleyball Camp	65	58
Cookie Decorating (June Session)	11	15

- Upcoming July Programs: Gymnastics (Level 3&4), Art Camp, Kids Camp (Sessions #2 & #3), Taekwondo (Summer #2), 4's Grass Volleyball League, Art Cart Extra, Viking Volleyball Camps, Cheerleading Camp, Pottery, Project Runway Sewing Camps, Exploring Clay, Soccer, Intro to Kayaking, Toddler Yoga, Swim Lessons (Session #2 & #3), Cooking Decorating (Session #2), Tree Climbing (July Session).
- We currently have 60 paid shelter rentals for 2025.
- Our USTA Family Tennis Day was held on Saturday, July 12th at 10am. This is a new event we ran for 2025 and due to the weather, we did not have as great of a turnout. We are looking to run another one in the fall in hopes to get a better turnout.

5. We sold 275 family pool passes and 74 individual pool passes for the 2025 season. We are up 34 family pool passes and down three individual pool passes from 2024. Happy to see the increase in family passes sold.
6. Our pool staff has been doing a great job this summer. This year, we implemented weekly in-service trainings every Friday before open swim, allowing staff to sign up for the ones they prefer. We asked each staff member to attend two trainings in June and July and one in August.
7. Culver's Scoopie will be visiting our pool on Tuesday, July 22 from 3-4pm.
8. Our frozen fun 'Splash Bash' is set for Thursday, July 24th from 1-5pm at the pool. We will have music from a live DJ, an inflatable water slide, games, and door prizes. Kona Ice will also be on-site selling frozen treats.
9. Our pool rentals are now complete for the summer. We hosted 18 rentals this season and received a great deal of positive feedback on how much people appreciate having this option available.



Village of Mount Horeb

Public Services Department

138 E Main St
Mount Horeb, WI 53572
Phone (608) 437-3351/Fax (608) 437-3190
www.mounthorebwi.info

Parks, Recreation and Forestry Commission

July 22, 2025

Public Services Director's Report

1. We are planning to excavate for the new playground equipment at Grundahl Park the week of July 21.
2. Staffing update:
 - Our arborist/parks crewman Slater Diederich is resigning. His last day is July 25. We will try to do as many tree removals and priority pruning as possible before he leaves.
 - We have an offer in to an applicant for the vacant mechanic/crewperson position and are waiting to hear back.
3. We measured out and painted 9 soccer fields and set up fields for the Rec Department's soccer program.
4. Ron Haag (RWH Plumbing) has performed a lot of plumbing repairs in the parks over the years. This year, he has worked on repairs at Waltz Park, Grundahl Park and the aquatic center. He has donated his labor for all three of those projects in the amount of \$600. We appreciate his help over the years and his sense of pride and support for the Village's parks and the community.